



Features

- ❑ Output in G's In./Sec, and Inches Displacement
- ❑ Internal Impedance Converter
- ❑ A Constant Current Source
- ❑ Selectable Gain Settings
- ❑ Selectable Low-Pass Filters

DESCRIPTION

The PA89 is a complete vibration monitoring amplifier plug-in module to the Validyne MC1 multichannel Transducer Systems. Through a coaxial connector on the front panel, piezoelectric accelerometers are connected directly to an internal impedance converter.

A connector on the rear panel of the MC1 case provides a constant current source and input for operation with an external impedance converter. A switch on the front panel selects either internal or external impedance converter operation. This switch also has a position which disconnects both inputs so that a test point jack on the front panel may be used as a calibration signal input. During normal operation the test point may be used for monitoring the signal which is going into the amplifier after the impedance converter.

Two outputs are provided. One provides ± 10 V peak, at 100 mA, capable of sustaining a direct short indefinitely without damage to the amplifier. A second output is attenuated to $+ 1$ V peak. The attenuation factor may be changed to suit a particular situation.

The function switch allows for the proper selection of non-integrating and integrating amplifiers such that the output is proportional to Acceleration (g's), Velocity (in./sec) or Displacement (inches).

Then, with seven selectable gain settings and a 10-turn continuous sensitivity adjustment the output can be adjusted to read out acceleration, velocity, or displacement in equivalent engineering units or other convenient units.

Internally selectable low-pass filters provide for the modification of the 20 kHz frequency response to 60, 200, 600 and 2000 Hz.

All power requirements of the PA89 are supplied by the MC1 Module Case.

Specifications

Input:	
Internal Converter:	Single ended output from piezoelectric accelerometer, shunt resistance of 510 megohms shunted by 6 pf capacitance
External Converter:	4 mA constant current provided for single-ended external impedance converter
Gain:	Switch-selectable steps of 10, 25, 50, 100, 250, 500, and 1000 times referred to Output A
Gain Vernier:	Continuously variable, 0 to 100% at each gain setting
Output:	A ± 10 volts peak @ 100 mA; B: ± 1 volt peak @ 10 mA short circuit. (Output voltage can be changed by changing internal resistors.)
Output Impedance:	A: Less than 1 ohm; B: Approximately 100 ohms
Frequency Response:	Flat +5%. 2 Hz to 20 kHz wide band selectable low-pass filter of 60, 200, 600 and 2000 Hz
Harmonic Distortion:	1% maximum
Residual Noise:	0.5% FS maximum, 0 to 20 kHz
Operating Temperature:	0°F to 160°F
Power Requirements:	± 15 Vdc supplied from MC1 module case
Input Connections:	Accelerometer input on front panel. External Converter input on MC1 case back panel

TYPICAL APPLICATIONS

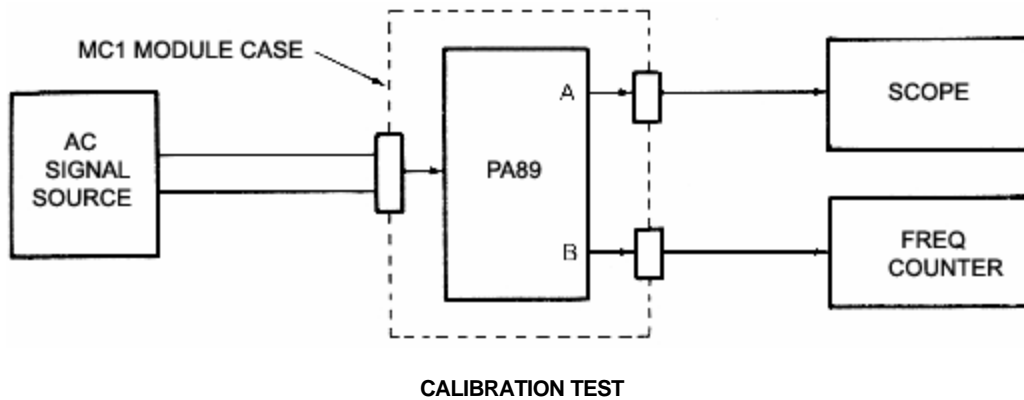
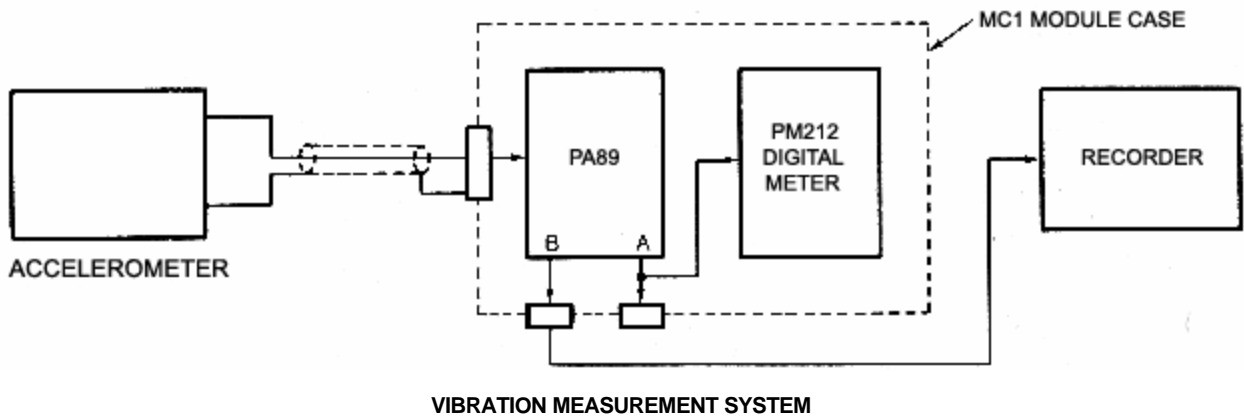
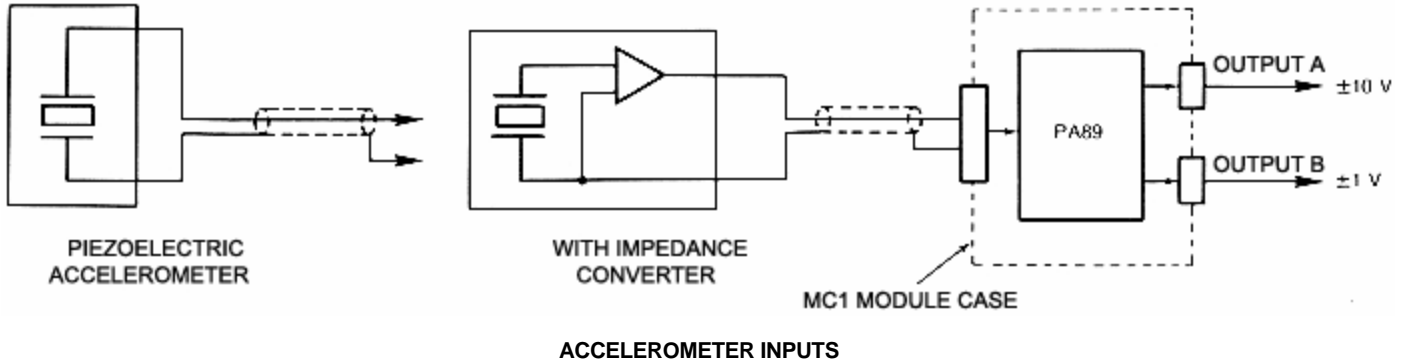

Accessories

P/N 7616-2 Plug-In Module Connection Extender