



Features

- Very High Gain (0.1 mV/V)
- Ten-Position Gain Switch
- Reference Phase Control ($\pm 90^\circ$)
- Three-Position Low Pass Filter Control
- Multiple Carrier Frequency Operation (400 Hz to 20 kHz)
- Dual Outputs

DESCRIPTION

The CD90 is a very high gain, dual output, Carrier Demodulator plug-in module for use with Validyne's MC1 System. The unit is used to provide transducer excitation and to amplify and demodulate the output of carrier-excited strain gage bridges and transducers, variable reluctance transducers, potentiometric transducers, linear and rotary variable differential transformers (LVDT/RVDT).

The CD90 will operate with full-bridge or half-bridge transducers delivering 10 Vdc output for inputs of 0.1 mV/V. A 10-position gain switch and 10-turn vernier potentiometer allows use of input signals from 0.1 mV/V to 500 mV/V.

The CD90 has a high-low balance range control. Additionally, a reference phase control ($\pm 90^\circ$) is provided for long line and reactive source operation. A front panel calibration switch provides + shunts calibration.

A 3-position frequency response control selects the appropriate output low-pass filter (30 Hz, 150 Hz and 750 Hz).

The CD90 may be operated with any carrier frequency from 400 Hz to 20 kHz by changing a plug-in control board.

Specifications

Input Sensitivity:	0.1 mV/V for 10 Vdc output (equivalent to 5 micro strain per volt of output, using a 4 active arm strain gage bridge with a gage factor of 2)
Gain Switch Steps:	0.1, 0.25, 0.5, 1-0, 2.5, 5.0, 10, 25, 50 and 100 mV/V
Input Attenuator:	Calibrated 10-turn potentiometer 0 to 100%
Maximum Input:	500 mV/V (2.5 Vrms) with gain switch at 100 mV/V and attenuator at 20%
Bridge Configuration:	2 or 4 arm strain gage (min. 100 ohm), variable reluctance, variable differential transformers (LVDT) and similar transducers

Specifications

Bridge Excitation:	Buffered, grounded center tap 5 Vrms 3 kHz into min. 100 ohm load. (See "Alternate Carrier Frequency Operation".)
Balance Controls:	Calibrated 10-turn in phase (R) balance. Screwdriver adjustable 15-turn quadrature (C) balance
Balance Range:	High range +25 mV/V, R & C balance; Low range +2-5 mV/V, R & C balance
Reference Phase Adjustment:	+90°, single turn screwdriver phase adjustment
Third Harmonic Filter:	Adjustable low level third harmonic filter allows high gain operation with inductive devices having large third harmonic content in their output
Output Filters:	Switch selectable low pass filter bandwidths of 1/100, 1/20, or 1/4 times the carrier frequency, with 5-pole response in the wideband position. (See Alternate Carrier Frequency Operation.)
Output: A & B:	± 10 Vdc at 100 mA, short circuit proof. Maximum output ± 15 V
Output Impedance:	A: Less than 10 ohms; B: 100 ohms standard
Linearity:	Less than $\pm 0.05\%$ of full scale
Output Noise:	Less than 10 mVrms with 750 Hz filter, less than 1 mV rms with 150 Hz or 30 Hz filter
Calibration:	Front panel jack for plug-in shunt calibration resistor Toggle switch for plus-off-minus calibrator control
Carrier:	Buffered grounded center-tapped bridge excitation, provides 5 Vrms into 100-ohm load. Requires 2.5 Vrms single-ended from module case (or external oscillator). Input impedance is 12.4 kohm shunted by 220 pf
Alternate Carrier Frequency Operation:	The CD90 may be operated with carrier frequencies from 400 Hz to 20 kHz. At each carrier frequency a separate "Frequency Matching" plug-in assembly (#7722) and "Output Filter" plug-in assembly (#7723] are required Plug-in assemblies are available for carrier frequencies of: 400 Hz, 3 kHz, 5 kHz, 10 kHz and 20kHz which are easily changed in the field. Unless otherwise specified, the CD90 is shipped with 3 kHz carrier plug-in assemblies.

TYPICAL APPLICATIONS

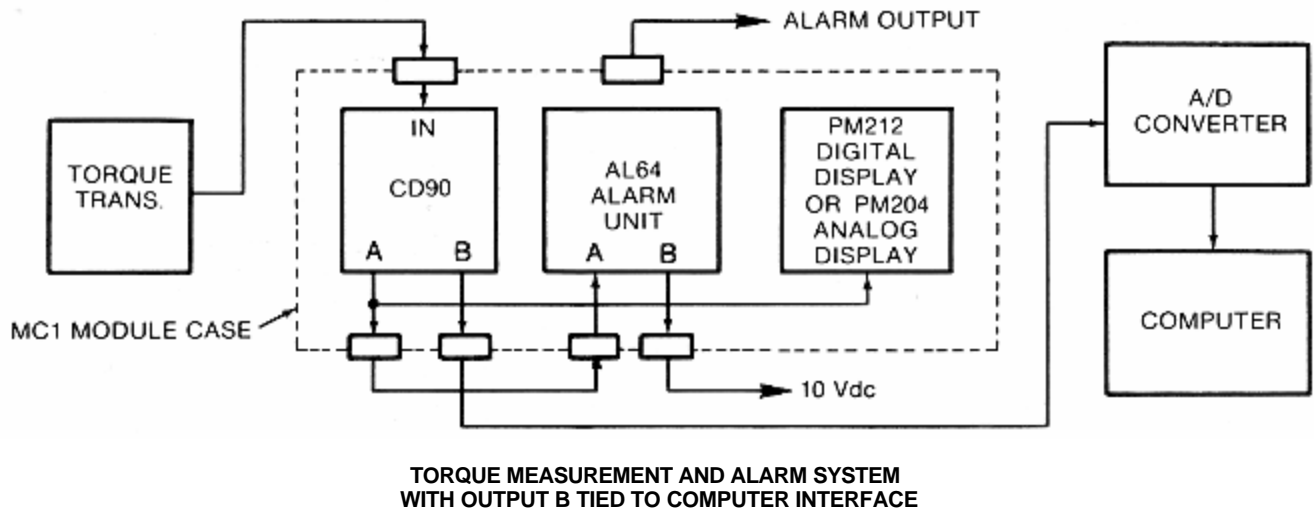
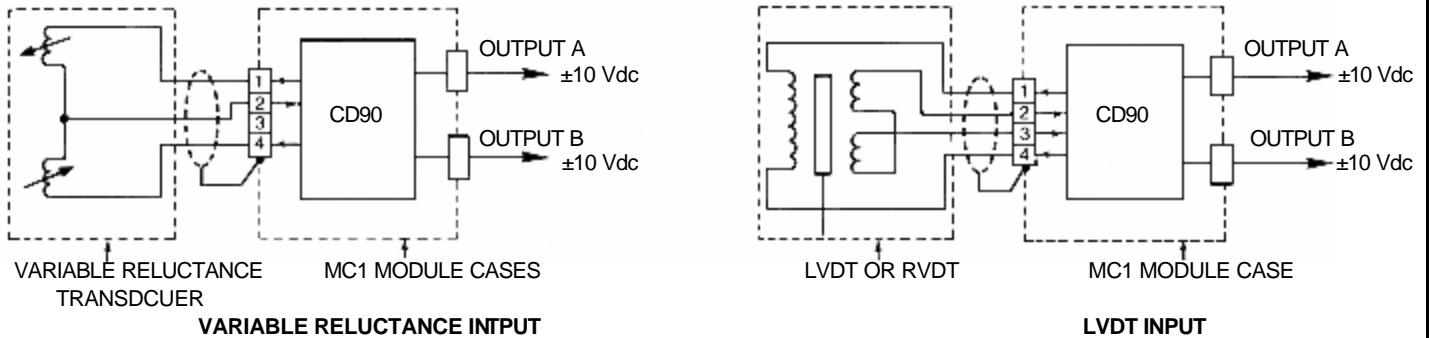
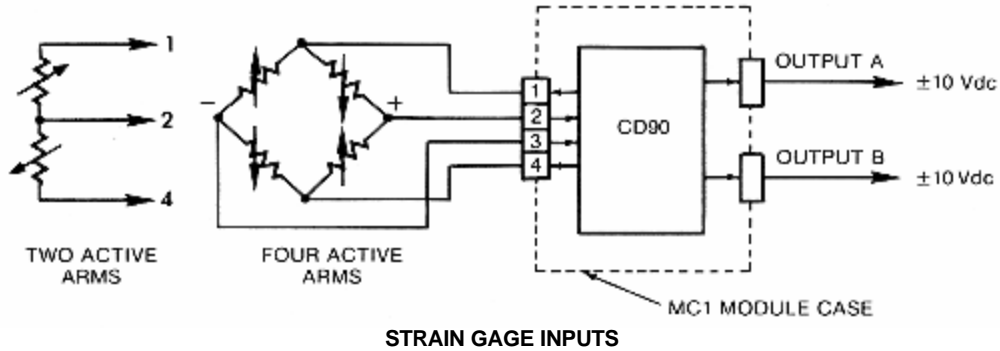

ACCESSORIES

P.N 7616-2 Plug-In Module Extender Card

P/N 7722-"X" – CD90 Frequency Matching Plug-In Assembly

Required to match a CD90 to a specific MC1 carrier frequency. See following table for "-X" frequency designation

P/N 7723-"X" – CD90 Output Filter Plug-In Assembly

Required to match CD90 filter characteristics to specific MC1 carrier- frequency. See following table for "-X" frequency designation.

FILTER DASH NUMBER (X) IDENTIFICATION TABLE

"-X"	Carrier Frequency
-1	3 kHz
-2	5 kHz
-3	10 kHz
-4	20 kHz
-5	400 kHz



8626 Wilbur Avenue - Northridge, CA 91324-4498
 (818) 886-2057 - FAX (818) 886-6512
<http://www.validyne.com> - e-mail to sales@validyne.com