



## DESCRIPTION

The CD257 Carrier Demodulator is designed as a plug-in module for the Validyne MC1 Modular System. When this unit is plugged into any position in the Validyne MC1 System Module Case, it provides excitation power for variable reluctance and LVDT transducers. It also provides a dual 10 Vdc output for minimum 15 mV/V input.

The CD257 contains a 10 Vdc suppression circuit and a X10 gain amplifier circuit. The suppression circuit is front panel selectable and can be switched in or out. The suppression control is a 10-turn potentiometer mounted on the front panel. Output gain is also front panel selectable and can be switched to X1 or X10. The suppression and gain features modify output B.

In addition, the CD257 features a reference phase adjustment for long lines between the carrier demodulator module case and the transducer. This adjustment is front panel adjustable. The unit also has a selectable low-pass filter switch on the front panel. The filter positions are 0.1, 1.0, 10, 50, 200, and 1000 Hz. System adjustments are easily made using the front panel ZERO and SPAN controls and the front panel output test points.

## Features

- Zero Suppression Control with Selectable Polarity
- Selectable Output Gain Amplification
- Dual  $\pm 10$  V Output
- Selectable Low-Pass Filter
- Reference Phase Adjustment for Long Transmission Lines

## Specifications

<b>Input Sensitivity:</b>	$\pm 15$ mV/V minimum for $\pm 10$ Vdc full scale output.
<b>Transducer Excitation:</b>	5 Vrms, 3 kHz from a precision center-tapped transformer
<b>Transducer Configuration:</b>	2-arm variable reluctance and LVDT transducers.
<b>Input Impedance:</b>	94 kohms
<b>Zero Control:</b>	$\pm 10$ mV/V (front panel screwdriver adjustment)
<b>Span Control:</b>	0 to 100% (front panel screwdriver adjustment)
<b>Output A:</b>	$\pm 10$ Vdc at 10 mA.
<b>Output B Characteristics:</b>	
<b>Output Voltage:</b>	$\pm 10$ Vdc at 10 mA
<b>Suppression:</b>	Calibrated 10-turn dial for 0 to $\pm 10$ Vdc suppression
<b>Suppression Control:</b>	Mode switch selects plus (+), minus (-), or Out (off).
<b>Gain Selection:</b>	Gain switch selects X1 or X10 amplification of suppressed output.
<b>Linearity:</b>	$\pm 0.05\%$ full scale maximum.
<b>Output Noise:</b>	Less than 10 mVrms at 10 Vdc.
<b>Frequency Response:</b>	Switch-selectable low-pass filter for cutoff frequencies of 0.1, 1.0, 10, 50, 200 or 1000 Hz.
<b>Reference Phase Adjust:</b>	Front panel screwdriver adjustment compensates for long transmission line applications, up to 10,000 feet.
<b>Temperature Range:</b>	0° to 160°F (-17.8°C to +71°C)
<b>Thermal Effects:</b>	
<b>Zero:</b>	0.005%/°F
<b>Span:</b>	0.01%/°F
<b>Power Required:</b>	5 Vrms, 3 kHz and $\pm 15$ Vdc supplied by MC1 Module Case.

## TYPICAL APPLICATIONS

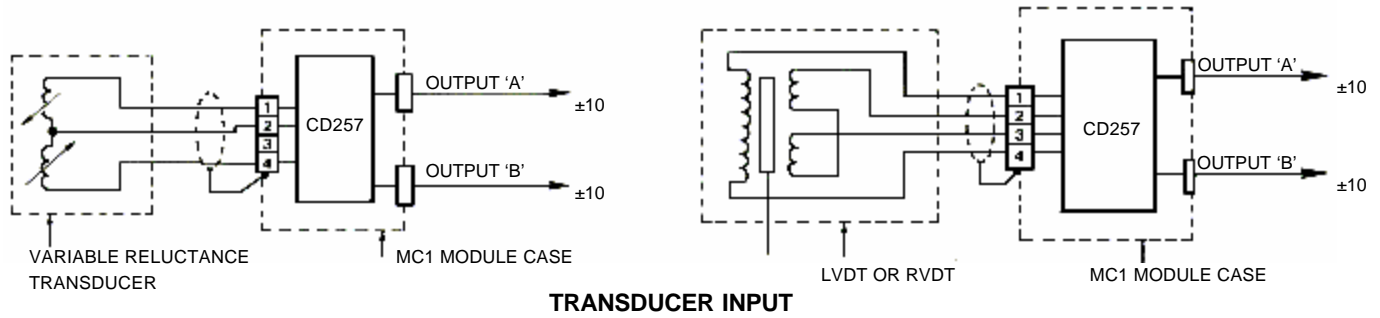

TRANSDUCER INPUT

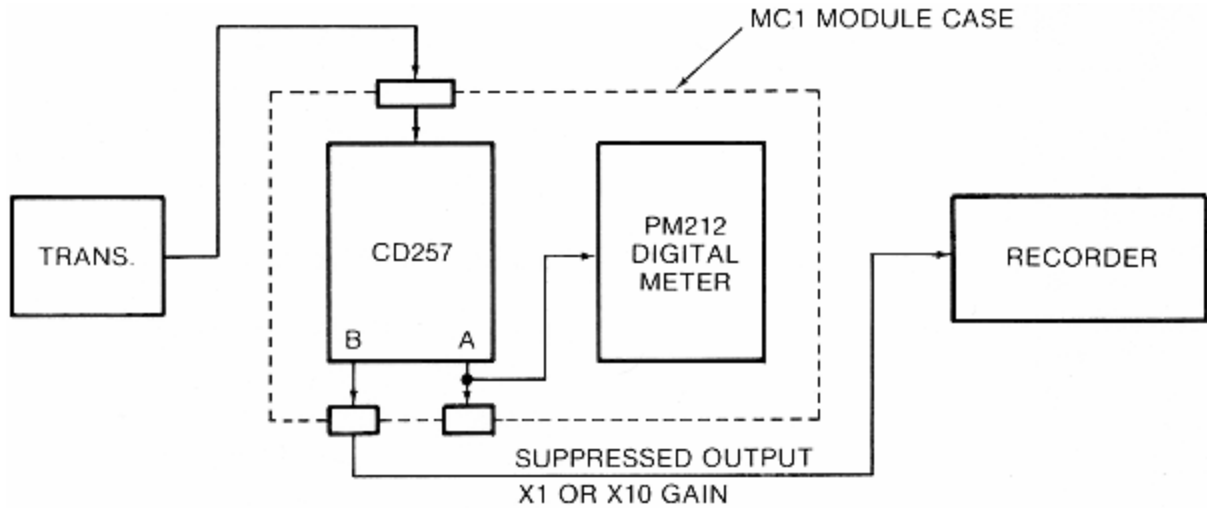

PRESSURE OR POSITION MEASUREMENT SYSTEM

## TRANSDUCER SELECTION CHART

### DIFFERENTIAL & GAGE PRESSURE TRANSDUCER

TRANSDUCER MODEL	MAXIMUM LINE PRESSURE (PSIG)	FULL SCALE MEASUREMENT RANGES	SPECIAL FEATURE
DP45	15	±0.032 to 12.5 PSID	Low Range
DP103	100	±0.008 T to ±12.5 PSID	Ultra-Low Range
DP10	3200	±0.08 to ±3200 PSID	All Welded
DP15	3200	±0.08 to ±3200 PSID	Wide Range
DP215	3200	±8 to ± 3200 PSID	17-7 PH S.S. Wide Range
DP303	5000	±0.08 to ± 5000 PSID	Hi Line, Low Range
DP22	12500	±50 to ±12500 PSID	Hi Line, Hi Range

### ABSOLUTE PRESSURE TRANSDUCER

TRANSDUCER MODEL	MEASUREMENT RANGES	SPECIAL FEATURE
AP10	0-0.08 to 3200 PSIA	All Welded

Specifications subject to change without notice.



8626 Wilbur Avenue - Northridge, CA 91324-4498  
 (818) 886-2057 - FAX (818) 886-6512  
<http://www.validyne.com> - e-mail to sales@validyne.com